

## 1550nm 3-port High Power PM Optical Circulator-30W

### Key Features

- Low Insertion Loss
- High Power Handling
- High Isolation
- PM and Non-PM are available
- Fiber can be customized
- High Reliability
- Excellent Temperature Stability

The 1550nm 3-port High Power PM Optical Circulator-30W is a compact, high performance light wave Polarization Maintaining component that routes incoming signals from Port 1 to Port 2, and incoming Port 2 signals to Port 3. So, fiber optic circulators act as signal routers, transmitting light from an input fiber to an output fiber, but directing light that returns along that output fiber to a third port. They perform a similar function as an isolator, protecting the input fiber from return power, but also allowing the rejected light to be employed.

If you do not see a standard Optical Circulator that meets your needs, we welcome the opportunity to review your desired specification and quote a custom circulator. Requests for custom fiber pigtails, different wavelengths and handling power of operation or other specific needs will be readily addressed.

### Applications

- High Power Fiber Lasers
- High Power Fiber Amplifier
- Instrumentation
- Test and Measurement
- Fiber Amplifier Lab Research



### Package Dimension

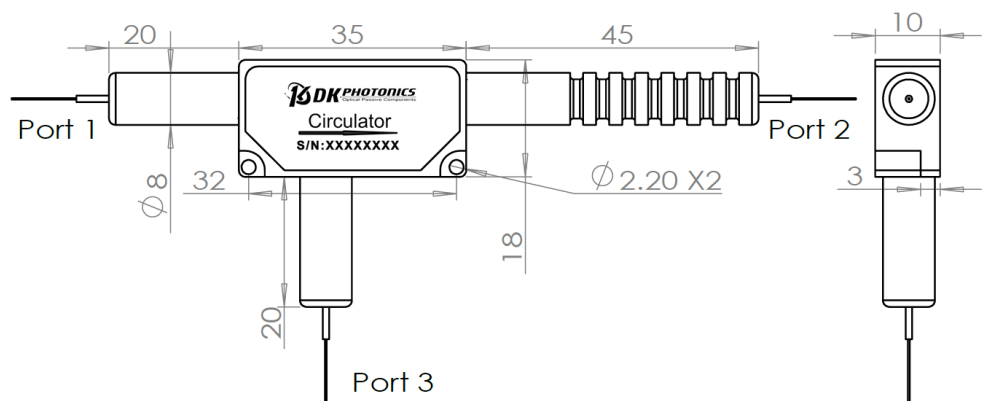

\*Due to ongoing design improvements, the package size is subject to change. Please contact DK Photonics for confirmation if you have special requirements.

## For more Info

### Please contact us at:

Tel: +86-755-23736280

Fax: +86-755-26746512

E-mail: [sales@dkphotonics.com](mailto:sales@dkphotonics.com)

<https://www.dkphotonics.com>

Add.:

4F, Bldg. 18, Qinghu Industrial Park,

Dahe Road, Longhua Dis.,

Shenzhen, China 518109

## 1550nm 3-port High Power PM Optical Circulator-30W

### Performance Specifications

Parameter	Unit	Values
Operating Wavelength	nm	1550
Operating Wavelength Range	nm	±15
Min. Isolation at 23°C, λc±15nm	dB	28
Max. Insertion Loss at 23°C, λc±15nm	dB	0.8
Min. Extinction Ratio (for PM fiber)	dB	18(Type B), 20(Type F)
Min. Return Loss	dB	50
Min. Crosstalk (Port 1->Port 3)	dB	45
Max. Optical Power (CW)	W	10, 20, 30
Max. Peak Power for ns Pulse if any	KW	5, 10, 20 (for typical pulse application)
Fiber Type	-	PM1550-XP or PM-GDF-12/130-M, PLMA-GDF-25/300 fiber
Operating Temperature	°C	-5~+70
Storage Temperature	°C	-40~+85

- Above specification are for device without connector and may change without notice.
- IL is 0.3 dB higher and RL is 5 dB lower, ER is 2dB lower for each connector added.
- The pass optical power is 2 W only for connector added, the connector is only used for performance testing at low power, higher power requires splicing fibers.
- Type B: Both axis working, Type F: Fast axis blocked, the default is Type B if without request .
- If there is pulse application, please be sure to inform us of pulse energy and peak power.

### Order information

P/N: HPPMOC-B/F-①-②-③-④-⑤-⑥-⑦

When you inquire, please provide the correct P/N number according to our ordering information and attach the appropriate description would be better. If need any connector, we do not recommend choosing a 250μm bare fiber pigtail. For high power applications, we recommend direct splicing without connectors.

①	②	③	④	⑤	⑥	⑦
Port	Operating Wavelength	Power Handling	Fiber type	Pigtails Diameter	Fiber Length	Connector
3:3-port	15:1550nm XX: Others	5:5W 10:10W 20:20W 30:30W	XXX: fiber code	25:250μm bare fiber 90:900μm Loose tube XX: Others	05:0.5m 10:1.0m 15:1.5m XX: Others	00: None FP: FC/PC FA: FC/APC XX: Others

**Part Number Example:** HPPMOC-F-3-15-10-P15X-25-10-00

**Description:** 1550nm 3-port HP Polarization Maintaining Optical Circulator ,10W, Fast axis blocked, PM1550-XP fiber, with bare fiber, 1.0m length fiber and no connectors at all ports.

### Ordering Information for Custom Parts

If you need to customize other specifications, please provide detailed description for your requirement.